



The Valve Company

CAST STEEL DOUBLE DISC METAL SEAL PARALLEL GATE VALVE 600Lb

Applicable standards:

STEEL GATE VALVES, API 600/API 6D
 STEEL GATE VALVES, ISO 10434/ISO 14313
 STEEL VALVES, ASME B 16.34
 FACE TO FACE, ASME B 16.10
 END FLANGES, ASME B 16.5
 BUTTWELDING ENDS, ASME B 16.25
 INSPECTION AND TEST, API 598/API 6D

Design description:

FULL PORT DESIGN
 OS & Y, OUTSIDE SCREW AND YOKE
 BB, BOLTED BONNET
 "V" WITH LEADING TO DISC
 CHOICE OF SOLID OR SPLIT WEDGE
 RENEWABLE SEAT RINGS
 FORGED T-HEAD STEM
 RISING STEM AND NON-RISING HANDWHEEL
 FLANGED OR BUTTWELDING ENDS
 AVAILABLE WITH BG OPERATOR

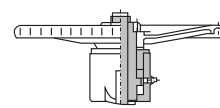
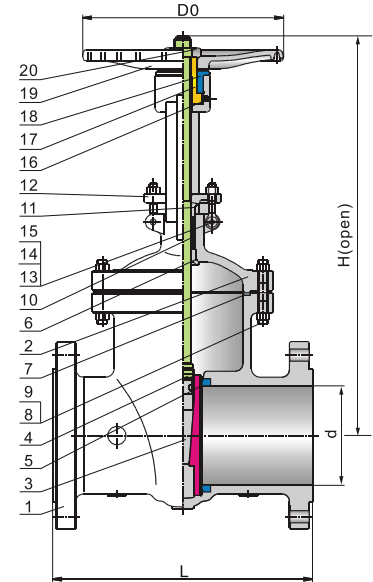

For NPS10 & Larger

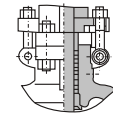

Yoke For NPS10 & Larger

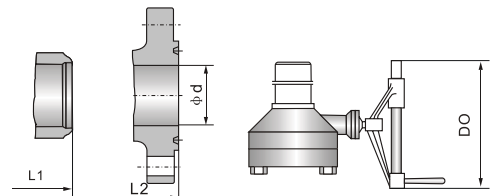

RTJ End

Materials of parts

No	Part Name	ASTM Material		
		Carbon Steel	1 1/4Cr-1/2Mo	Carbon Steel
1	Body	A216-WCB	A217-WC6	A352-LCB
2	Bonnet	A216-WCB	A217-WC6	A352-LCB
3	Wedge	A216-WCB+CR13	A217-WC6+HF	A352-LCB+CR13
4	Stem	A182-F6a	CR-MO-V	A182-F6a
5	Seat Ring	A105+CR13	A182-F11+HF	A350-LF2+CR13
6	Stem Back Seat	A276-420	A276-304	A276-420
7	Bonnet Gasket	Spiral Wound (Graphite+304)		
8	Bonnet Stud	A193-B7	A193-B16	A320-L7
9	Bonnet Stud Nut	A194-2H	A194-7	A194-4
10	Packing	Graphite		
11	Gland	A276-420	A276-304	A276-420
12	Gland Flange	A216-WCB	A217-WC6	A352-LCB
13	Eyebolt Pin	Carbon Steel	A276-420	Carbon Steel
14	Eyebolt	Carbon Steel	A193-B7	Carbon Steel
15	Eyebolt Nut	Carbon Steel	A194-2H	Carbon Steel
16	Grease Fitting	Brass+Steel		
17	Yokesleeve	Aluminum-Bronze ¹⁾		
18	Yokesleeve Jam Nut	Carbon Steel		
19	Handwheel	Malleable Iron		
20	Handwheel Nut	Carbon Steel		

Note: 1) Ductile Ni-Resist optional

2) Wedge and seat ring may either be solid facing material or a base material equal to or better than the body/bonnet material with facing as shown.

Dimensions data

NPS	2	2 1/2	3	4	6	8	10	12	14	16	18	20	24	26	28	30	32	36	40	42	48	in
DN	50	65	80	100	150	200	250	300	350	400	450	500	600	650	700	750	800	900	1000	1050	1200	mm

ANSI Class 600Lb

L/L1 (RF/BW)	11.50	13.00	14.00	17.00	22.00	26.00	31.00	33.00	35.00	39.00	43.00	47.00	55.00	57.00	61.00	65.00	70.00	82.00	84.60	88.97	105.00	in
	292	330	356	432	559	660	787	838	889	991	1092	1194	1397	1448	1549	1651	1778	2083	2149	2260	2667	mm
L2 (RTJ)	11.62	13.12	14.12	17.12	22.12	26.12	31.12	33.12	35.12	39.12	43.12	47.25	55.38	57.50	61.50	65.50	70.62	82.62	-	-	-	in
	295	333	359	435	562	664	791	841	892	994	1095	1200	1407	1461	1562	1664	1794	2099	-	-	-	mm
H (OPEN)	16.50	18.75	20.38	25.50	33.00	40.38	48.38	57.00	62.00	70.62	76.00	87.00	101.50	105.00	109.50	114.00	124.00	140.00	141.73	155.51	181.10	in
	418	476	518	646	840	1025	1230	1450	1575	1795	1930	2210	2580	2665	2780	2895	3150	3560	3600	3950	4600	mm
(d)	50	63	76	100	150	199	247	298	326	374	419	463	558	603	648	695	781	876	-	-	-	mm
D0	8	10	10	12	18	20	24	24	24	24	26	26	29	29	32	32	38	40	28.34	28.34	28.34	in
	200	250	250	300	450	500	600	600	600	600	640	640	720	720	800	800	950	1000	720	720	720	mm
WT (kg)	36	52	67	112	170	393	610	890	1245	1530	1965	2450	2995	3475	3725	4045	4185	4480	14300	16400	22900	RF/RTJ
	29	42	53	83	125	310	472	730	1055	1240	1625	2030	2590	2855	3065	3440	3780	4085	-	-	-	BW
Toqure	23	-	50	68	183	270	479	650	988	1243	1512	2185	3053	-	-	5452	-	7675	-	-	-	mm